

VM-1 Application Board 2

Introduction

The 5805 is an Application Board for the VM-1 Control Module. The board provides interfaces to the VM-1's first RS232 serial port; the first I²C bus and a regulated 5VDC supply. All of the VM-1's connector pins are taken out to two prototyping areas so you can prototype your VM-1 application.

This board can also duplicate the flash in the VM-1, or create a new Venom-SC flash from an image file downloaded from our web site.

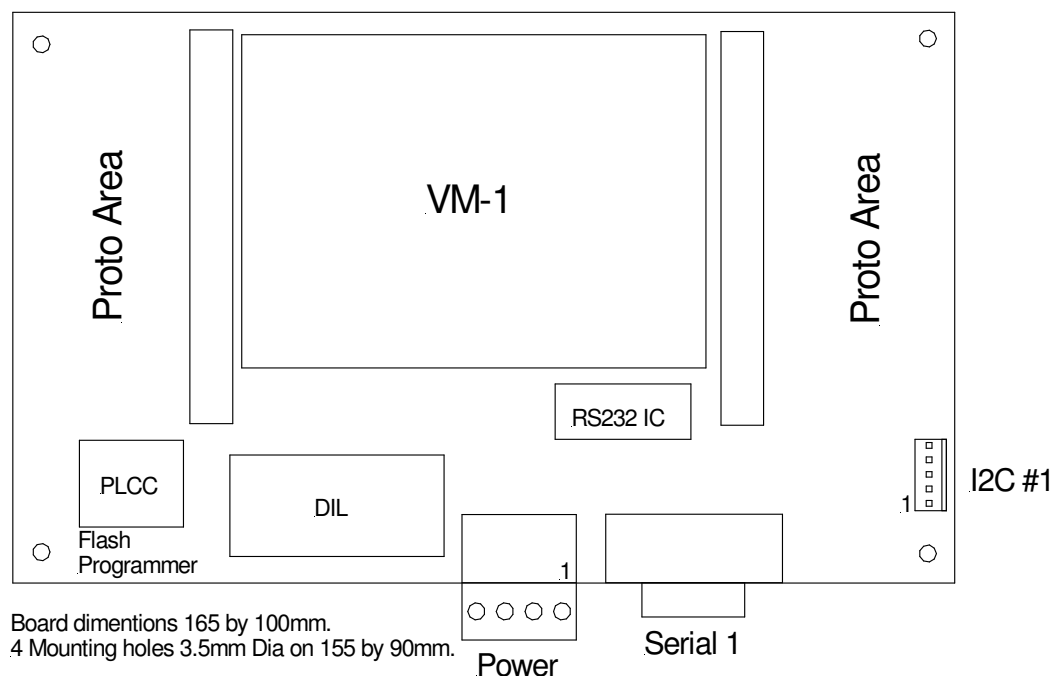

Unpacking

You should have:

- 5805 Breakout Board
- Power Connector
- These instructions

WARNING: Users of Micro-Robotics Control Equipment should be aware of the possibility of a system failure, and must consider the implications of such failure. Micro-Robotics Ltd. can accept no responsibility for loss, injury, or damage resulting from the failure of our equipment. Use of our products in applications where their failure to perform as specified could result in injury or death is expressly forbidden.

What you will need

To start using the application board you will also need:

- VM-1 Control Module (5800) with language ROM (5803).
- 8 to 30V, 100mA, unregulated DC power supply.
- An RS232 serial lead to connect the 5802 to your host computer. Use a lead that would be used to connect two PC's together (a 'Null Modem').
- A PC running terminal emulation (communication) software (for example, Hyper Terminal).
- The VM-1 and Venom-SC Manual set.

Serial Port 1 RS232

The 5805 has an RS232 level shifter IC to allow the VM-1 to talk to a host PC. This IC is fitted in a socket in case you need to remove it for your application.

Pinout

Connector: J1 - 9 way D-Type plug

Pin	1	2	3	4	5	6	7	8	9
Channel		13	14				12	11	
Signal	*	RXD	TXD	*	GND	*	RTS	CTS	N/C

* - These pins are connected to each other on the 5805.

Configuration

Serial port 1 is configured in the default startup procedure with the line:

```
MAKE serial AsynchronousSerial(38400,1,1)
```

I²C Bus

Pinout I²C Port 1

Connector: J2 - 5-way 0.1" header

Pin	1	2	3	4	5
Signal	Data	Clock	0V	5V	N/C
Channel	9	10			

Configuration

```
MAKE net I2Cbus ;creates the first bus
MAKE net I2Cbus(1) ;[does same as above]
```

Power Supply

The 5852 may be powered from a supply voltage range of 8 to 30 volts unregulated DC. The current consumption depends upon what is attached to the unit and whether the processor is idle, but is usually around 40 - 80mA.

There is also a regulated 5V output for powering external circuits. The regulator doesn't have a high capacity heat sink – just a wide copper area on the board under the VM-1, so can't support much more than 1 watt¹ of power dissipation at room temperature. Be careful of the regulator – it can get very hot.

To calculate the power dissipation in the regulator use $P = I * (V_{in} - 5.7)$

Where I is the total current in Amps and V_{in} is the input voltage.

Pinout

Connector: J3 - 4 way pluggable screw terminal. Plug provided.

Pin	1	2	3	4
Function	0v	5v Out	0v	Vin

¹ Tested to 2 Watts.

Prototyping areas

The two prototyping areas at each end of the board have sets of pads on a 0.1" pitch. The pads have been arranged around the common 0.3"-wide IC footprint, though many other through-hole components will also fit.

The pins of the VM-1 have been expanded to two sets of connector positions, JP3 & 4, in a one-to-one pattern. You can use these positions to take VM-1 signals to the prototyping areas with hook-up wire, or fit 0.1" connectors into them.

Here is the VM-1 pinout:

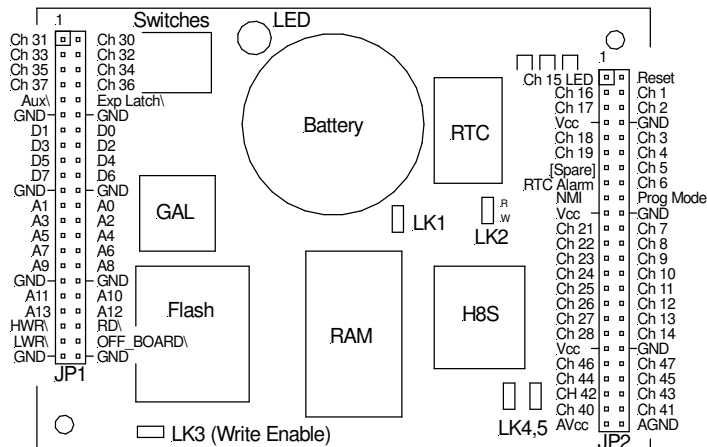

Flash programming sockets²

There are two flash programming sockets on the board: a 32-pin PLCC socket and a 32-pin DIL socket. These are connected with the same signals – they just provide a different connector format.

Normally you should use the PLCC socket.

The DIL socket is used when you are using a Zero-Insertion-Force PLCC socket fitted to a DIL carrier to program a large number of devices.

When you are using the flash programming facility you must be aware that VM-1 channels 30-37 will be used as address outputs to the flash device.

To make an exact copy of the flash in the VM-1

- Put a 29040 flash device in the programming socket
- Type the following command at the command line `Copy (0, TRUE)`
- Wait for the command line message saying programming is complete.

To program a flash device with a new Venom-SC version from our website³

- Download the file from our web site
- Put a 29040 flash device in the programming socket
- Type in the command `Copy (1, TRUE)`
- Wait for instructions to send the file
- Send the *entire* contents of the file, either using cut and paste or the 'Send text file' option on your terminal emulator. It is very important you send the complete file. Progress is indicated at the command line. The time taken to download the file is around 0.27 seconds per kilobyte at 38.4Kbaud.
- Wait for the command line message saying the download is complete.

The Copy command has more flexibility than is presented here – see the Venom-SC Help file for more information.

² You may copy the Venom-SC flash device as many times as you require, but the original and the copies may only be used in Micro-Robotics Ltd products.

³ You can use the 5805 to program any data into a flash, so long as it is in Motorola S-Record format.